

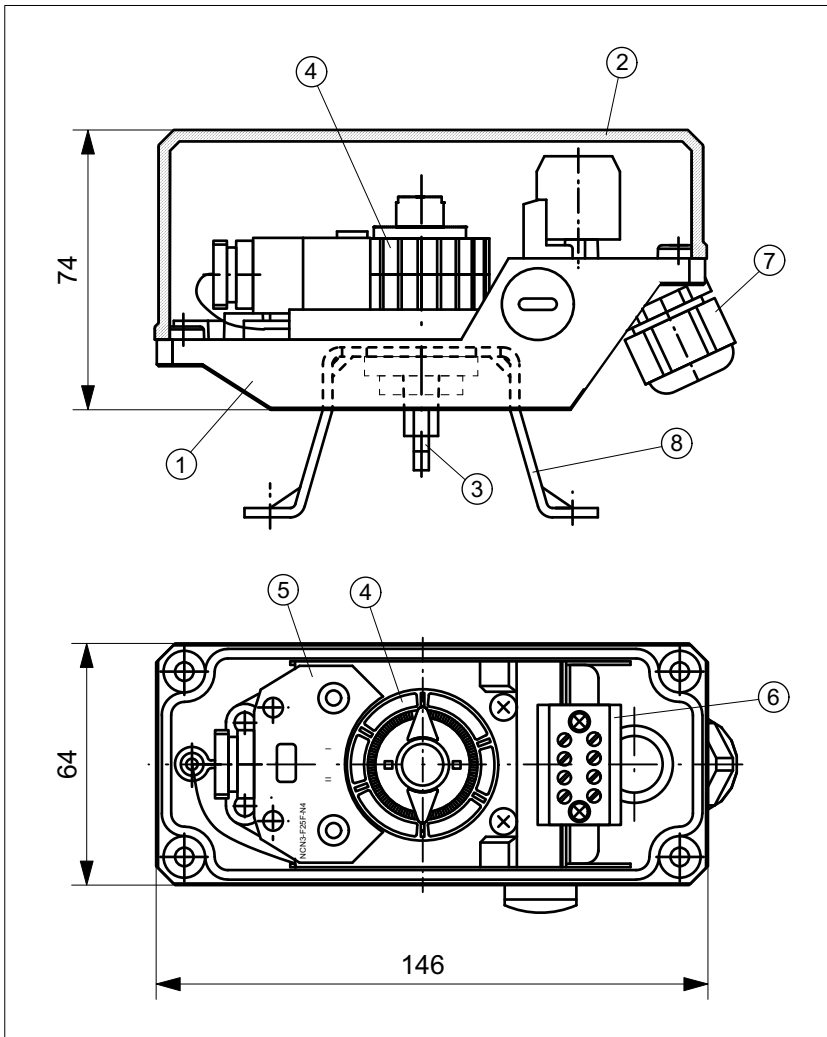

TPFF25NVVAZ

TCR-Module with double sensor Pepperl+Fuchs NCN3-F25F-N4
in TCR-Housing 146 x 64 x 74 mm



TECHNICAL DATA

Manufacturer: Pepperl+Fuchs
 Type: NCN3-F25F-N4
 inductive, NAMUR
 Normally closed contact

Operating distance: 3 mm
 Nominal voltage: 8,2 V DC
 Switch. frequency: 0 ... 1500 Hz
 Current consumpt.: ≥ 3 mA, inactive
 ≤ 1 mA, active

Output: short-circuit protection,
 reverse-polarity protection

Temperature: $-25 \dots +85^{\circ}\text{C}$
 Housing base: Vestamid, black
 Housing cover: Vestamid, black
 Sealing: EPDM
 Ingress protection: IP67 (Sensor)
 IP65 (Housing)

Switching precision: $< 1.5^{\circ}$
 System connection: Cable gland M20x1,5



II 2G Ex ia IIC T6 Gb

EC-Type Examination Certificate No.
TÜV 99 ATEX 1479 X

OBJECT LIST

Pos.	Pcs.	Description	Material
1	1	Housing base	Vestamid
2	1	Housing cover	Vestamid
3	1	TCR-Axis	POM
4	1	Switch cam system	POM + Al
5	1	P+F NCN3-F25F-N4	
6	1	Terminal block, 4-pole	-
7	1	Cable gland M20x1,5	-
8	1	Bracket size 1 - 4	A2

WIRING DIAGRAM

